

TYPE EVT-1200cE

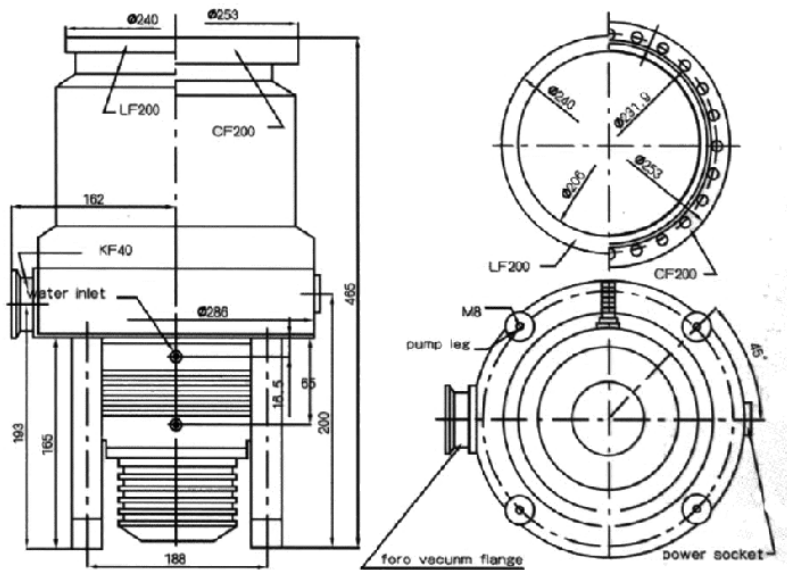
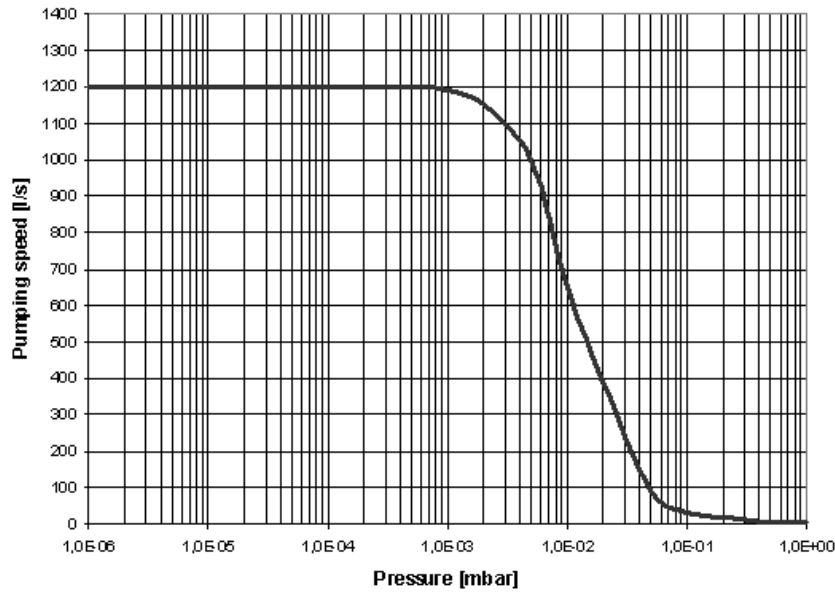

TYPE EVT-1200cE

Technical Data		TYPE EVT-1200cE	
		1200cE-LF	1200cE-CF
Pump type		Compound/Drag	Compound/Drag
Inlet Flange		200 ISO-K	200 CF
Fore vacuum Flange		40 KF	40 KF
Pumping speed (air)	l/s	1.200	1.200
Pressure for max. speed	mbar	1×10^{-2}	1×10^{-2}
Rotation Speed	rpm	24.000	24.000
H ₂ Compression Ratio		6×10^3	6×10^3
N ₂ Compression Ratio		1×10^9	1×10^9
Ultimate Vacuum	mbar	6×10^{-8}	6×10^{-9}
Run up Time	min	<6	<6
Control Unit		FD-1200KW	FD-1200KW
Input Voltage	VAC	220 ±10%	220 ±10%
Cooling water	l/min	> 2	> 2
Bearing type		Ceramic Grease	Ceramic Grease
Operating Orientation		Any	Any
Weight	kg	39	39

Ordering Information	TYPE EVT-1200cE	
	1200cE-LF	1200cE-CF
Turbo drag pump EVT-1200cE incl. splinter screen	812.100	812.101
Control unit type FD-1200KW	812.110	812.110
Cable 2,5 m	812.011	812.011
Cable 5 m	812.012	812.012
Cable 10 m	812.013	812.013
Cable 20 m	812.014	812.014
Other lengths	Upon request	Upon request
Heating jacket 230V AC	Upon request	Upon request
Venting valve NC 230V AC, 50/60Hz	250.533	
Venting valve NC 24V AC, 50/60Hz	250.531	
Venting valve NC 24V, DC	250.530	
Filter for venting valves	215.152	
Venting valve NO 200-230V, 50/60Hz	250.851	
Venting valve NO 24V, DC	250.850	
Delayed venting unit	Upon request	
Aircooling unit R-XT, 90 - 264V AC, 50/60Hz	800.010	
12V, DC	800.011	
Recommended fore pump: Standard operation Type EVD-TRP-48, 400V AC	424.902	
Purge gas operation Type EVD-TRP-60, 400V AC Also Dry pumps can be used	425.902	