

TYPE EVC-0100

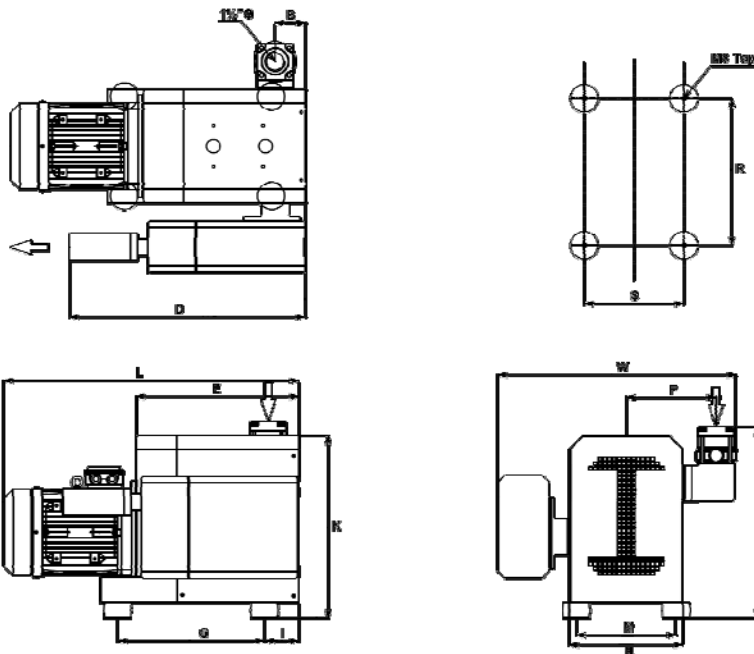

Pumping speed curve

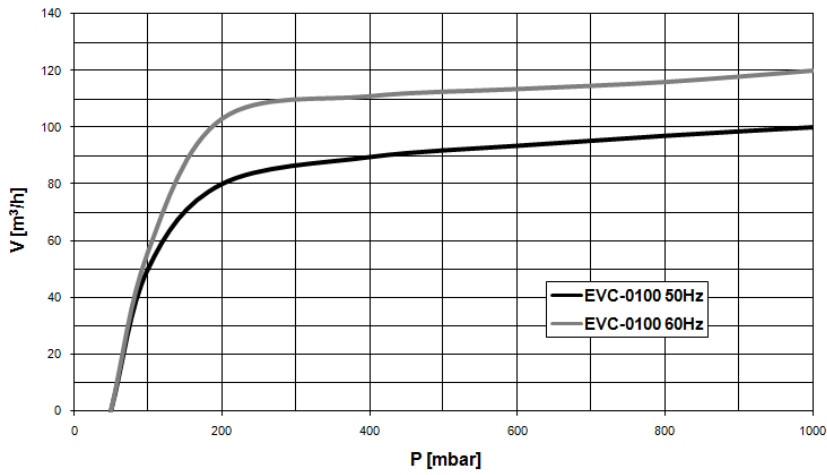

Dimensions	L	W	H	B	D	E	G	I	K	M	N	P	R	S	Tap
EVC-0100	698	545	405	91	553	394	440	79	368	224	254	212	440	224	M8

TYPE EVC-0100

Technical Data		TYPE EVC-0100	
		50 Hz	60 Hz
Nominal displacement	m ³ /h	100	120
Ultimate pressure max.	mbar	50	50
Pressure continuous running	mbar	150 to 1000	150 to 1000
Motor power	kW	2,2	3,0
Nominal speed	rpm	2850	3450
Noise level	dB(A)	78	82
Oil filling gear housing	ltr	0,5	0,5
Weight	kg	108	113
Admissible ambient temp.	°C	5 to 40	5 to 40
Connection	Inlet	NPT	1½"
	Outlet	NPT	1½"

Ordering Information	TYPE EVC-0100	
	50 Hz	60 Hz
Three phase motor 400V, 50Hz (IEC) 400V, 60Hz (IEC) 400V, 60Hz (NEMA)	602.001	602.002 602.003
Other Voltages/Frequencies	Upon request	
Vacuum regulate valve	602.010	
Exhaust damper	602.011	
Gasket set	602.012	
Maintenance kit	602.013	
Pump module	602.014	
Inlet dust filter, paper cartridge	602.025	