

# TYPE EVSL-60

**Available from July 2009**

**Pumping speed curve**

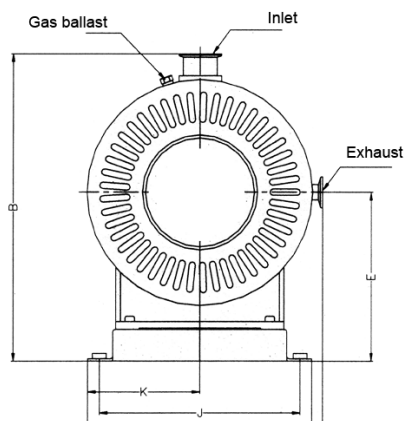
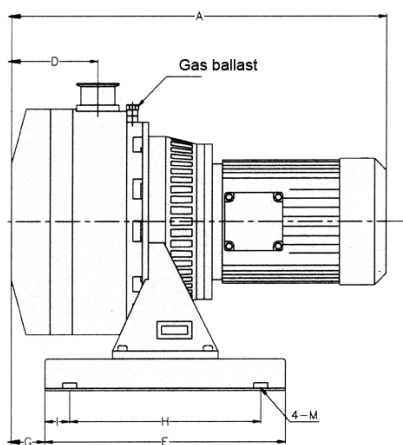
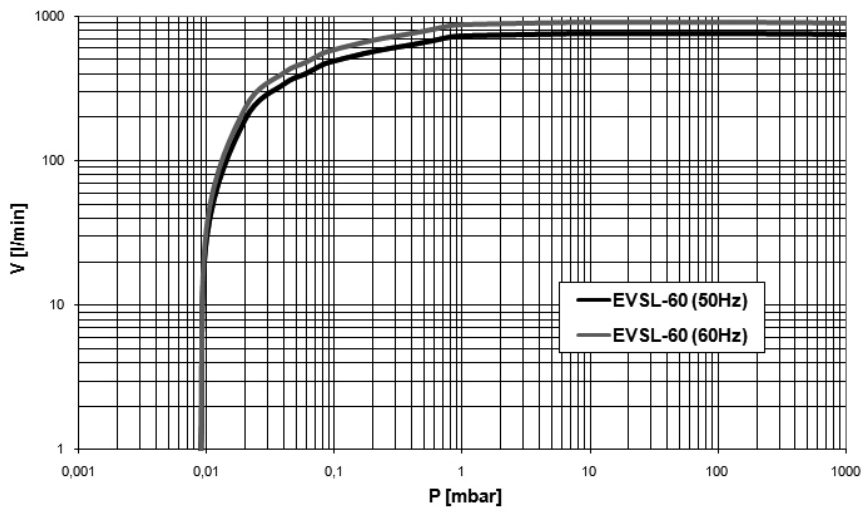

Dimensions	A	B	C	D	E	F	G	H	I	J	K	L	M
EVSL-60	593	450	386	152	338	350	55	280	35	296	160	320	M10

## TYPE EVSL-60

Technical Data		TYPE EVSL-60	
		50 Hz	60 Hz
Pumping speed	m <sup>3</sup> /h	54	65
Ultimate pressure max.	mbar	9·10 <sup>-3</sup>	9·10 <sup>-3</sup>
Leak rate	mbar·l/s	< 10 <sup>-4</sup>	< 10 <sup>-4</sup>
Max. inlet pressure	mbar	atmosphere	atmosphere
Motor power	kW	1,5	1,5
Nominal speed	rpm	2850	3450
Noise level	dB(A)	≤ 75	≤ 75
Weight	kg	72	72
Admissible ambient temp.	°C	5 to 40	5 to 40
Connection	Inlet	DIN 40 KF	40 KF
	Outlet	DIN 40 KF	40 KF

Ordering Information	TYPE EVSL-60	
	50 Hz	60 Hz
<b>Three phase motor</b> 400V, 50Hz (IEC) 400V, 60Hz (IEC) 400V, 60Hz (NEMA)	634.011	634.012 634.013
Other Voltages/Frequencies	Upon request	
Exhaust damper	634.100	
Minor kit (8000 hours)	634.801	
Major kit (16000 hours)	634.802	