

# TYPE EVSL-15

**Available from Apr. 2009**

**Pumping speed curve**

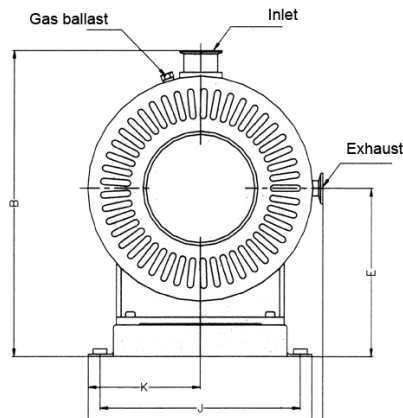
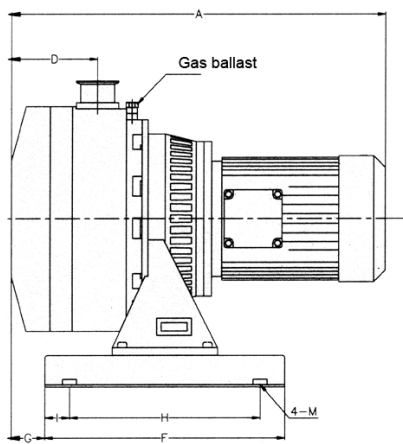
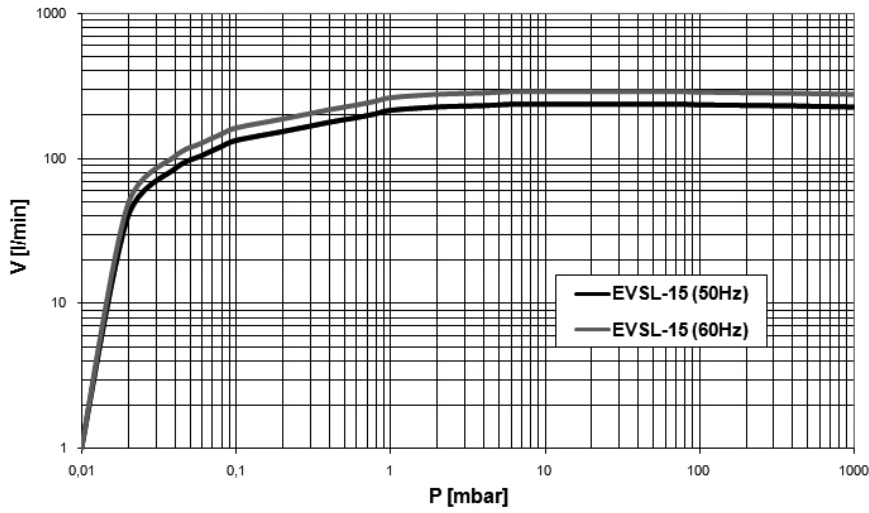

Dimensions	A	B	C	D	E	F	G	H	I	J	K	L	M
EVSL-15	453	335	180	108	188	170	121	130	20	136	90	180	11

## TYPE EVSL-15

Technical Data		TYPE EVSL-15	
		50 Hz	60 Hz
Pumping speed	m <sup>3</sup> /h	14,5	17
Ultimate pressure max.	mbar	$1,6 \cdot 10^{-2}$	$1,6 \cdot 10^{-2}$
Leak rate	mbar·l/s	$< 10^{-4}$	$< 10^{-4}$
Max. inlet pressure	mbar	atmosphere	atmosphere
Motor power	kW	0,55	0,55
Nominal speed	rpm	2850	3450
Noise level	dB(A)	≤ 65	≤ 65
Weight	kg	30	30
Admissible ambient temp.	°C	5 to 40	5 to 40
Connection	Inlet	DIN 25 KF	25 KF
	Outlet	DIN 16 KF	16 KF

Ordering Information	TYPE EVSL-15	
	50 Hz	60 Hz
<b>Single phase motor</b> 230V, 50Hz (IEC) 230V, 60Hz (IEC) 230V, 60Hz (NEMA)	632.001	632.002 632.003
<b>Three phase motor</b> 400V, 50Hz (IEC) 400V, 60Hz (IEC) 400V, 60Hz (NEMA)	632.011	632.012 632.013
Other Voltages/Frequencies	Upon request	
Exhaust damper	631.100	
Minor kit (8000 hours)	632.801	
Major kit (16000 hours)	632.802	